

# STATIONARY COMPACTORS

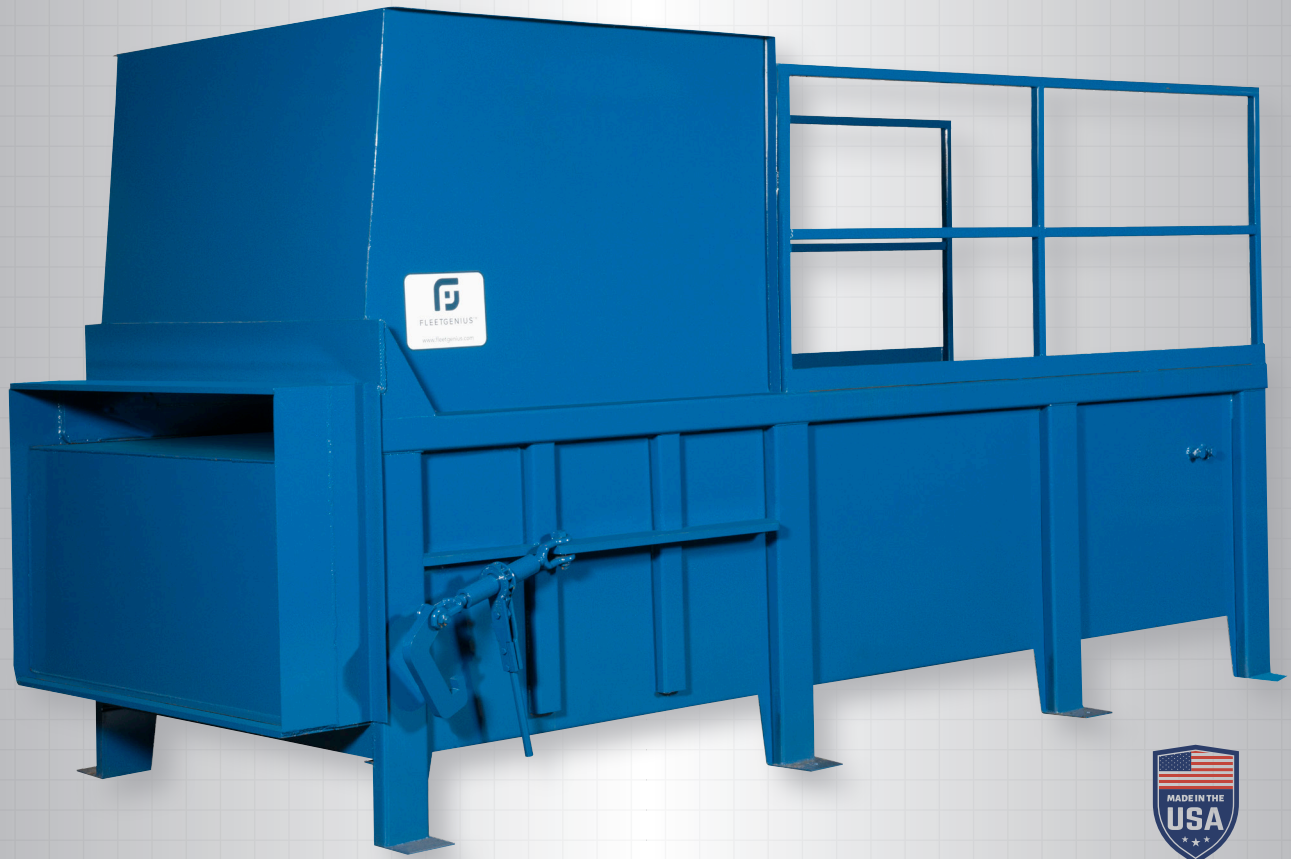

**COLLECT IT. CONTAIN IT. COMPACT IT.**



Perfect for Commercial  
& Industrial Applications



2-to-5 Cubic  
Yard Capacities



**FLEETGENIUS®**



Designed & Engineered for  
Strength & Dependability



"The Flex" Power Unit  
& Soft Shift Hydraulics

# Stationary Compactor Specs and Features

FleetGenius® Stationary Compactors, sometimes called a breakaway compactor, is a heavy-duty machine that compresses dry waste & recyclables to reduce their volume for disposal. Our Stationary Compactors are available in sizes ranging from 2 to 5 cubic yards. Stationary compactors are built separate from the compaction container, and is bolted to the ground during installation. When it is time for disposal, the compactor remains in place, while the container detaches and is hauled away.

With their powerful hydraulic systems and sturdy construction, breakaway compactors can help businesses save money on disposal costs, and reduce environmental impact, improving overall waste management efficiency. Sales, Service, Technical Support, Delivery, Installation and Parts are all available via our eight strategically located service centers within the US. FleetGenius® is your one-stop shop for all your compactor needs.

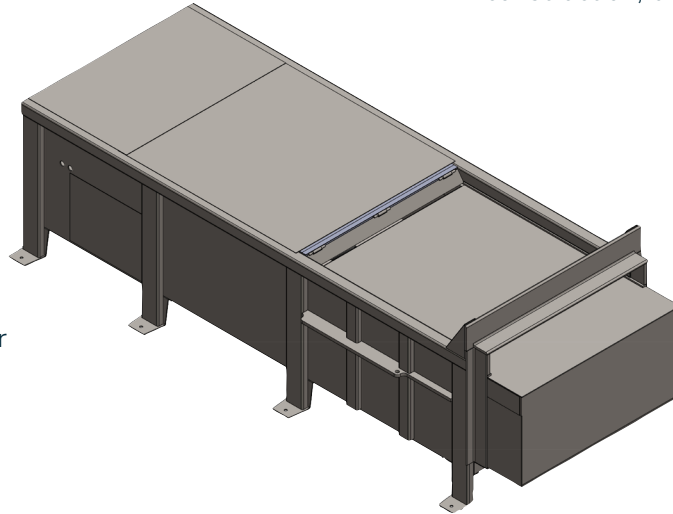

Side View

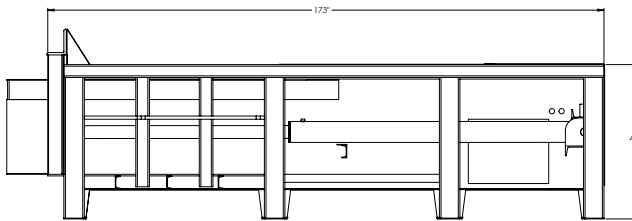

Top View

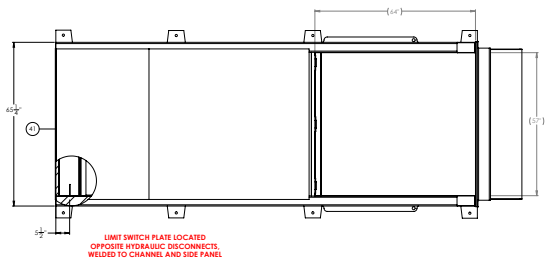

Rear View

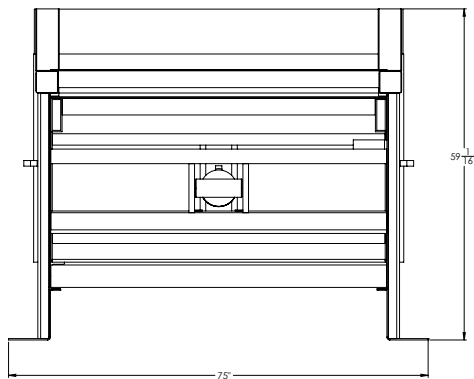

Front View

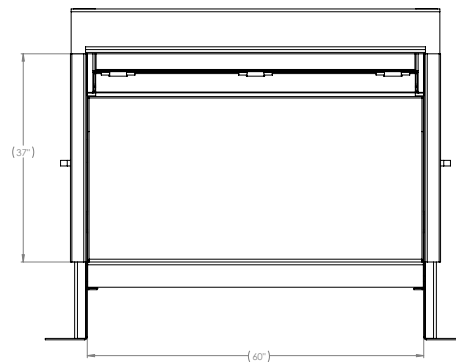

# S400 & Detailed Specs



	<b>S-200 (2 YD)</b>	<b>S-300 (3 YD)</b>	<b>S-400 (4 YD)</b>	<b>S-5000 (5 YD)</b>
Basic Size (cy)	1.58	2.31	2.71	4.22
A - Overall Length	120"	168"	168"	239"
B - Overall Height	48"	48"	54"	54"
C - Overall Width	66"	66"	66"	66"
D - Clear Top Openings (L x W)	46" X 60"	61" X 60"	61" X 60"	94" X 60"
E - Discharge Openings	37" X 60"	37" x 60"	41" x 60"	41" x 60"
Ram Penetration	11"	14"	14"	16"
Normal Force	58x400 lbs @ 2050 psi	48,400 lbs @ 1700 psi	48,400 lbs @ 1700 psi	65,000 lbs @ 1700 psi
Maximum Force	71,000 lbs @ 2550 psi	59,000 lbs @ 2100 psi	59,000 lbs @ 2100 psi	77,000 lbs @ 2100 psi
Ram Facing	60" x 29"	60" x 29"	60" x 34"	60" x 34"
Cycle Time	60 sec	60 sec	60 sec	100 sec
Motor	15 hp	15 hp	15 hp	15 hp
Pump	12 gpm	15 gpm	15 gpm	15 gpm
Cylinder (Diameter)	6"	6"	6"	7"
Rod / Stroke	2.5" x 56"	4" x 78"	4" x 78"	4" x 110"

# FLEETGENIUS® AT A GLANCE

At FleetGenius®, we've built our reputation on listening to our customers first, understanding their needs and then designing quality products that meet or exceed their expectations. FleetGenius® Stationary Compactors are ruggedly constructed to exacting standards to provide you with years of trouble-free performance without gimmicks or add ons you didn't ask for. In short, our compactors just work.

Genius? No. FleetGenius®.

## WHO ARE WE?

- FleetGenius® has grown to include multiple environmental services companies with a combined experience spanning decades.
- Along with manufacturing our own line of commercial equipment, we also offer commercial container management that includes: inventory management, cart poly-welding, container washing, and more!
- Although we do deliver equipment via our own fleet, don't be fooled by our name! FleetGenius® is not a logistics company - we just support them!

Interested in learning more? Visit us at [www.fleetgenius.com](http://www.fleetgenius.com) or give us a ring at 833-627-4872.

## Eight Strategically Located Sales/Service Distribution Centers and SuperCenters

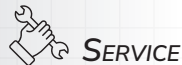
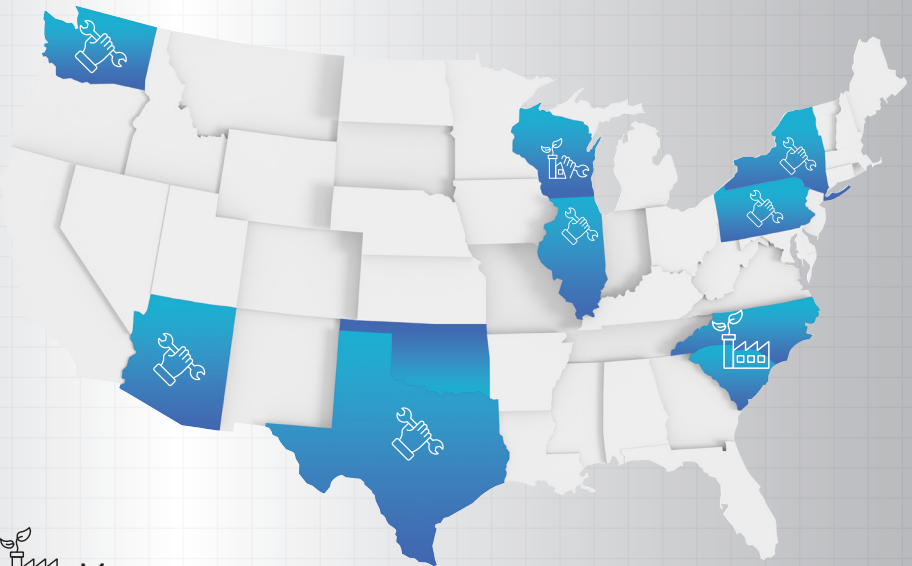

**FLEETGENIUS®**

[www.fleetgenius.com](http://www.fleetgenius.com)