

APARTMENT COMPACTORS



COLLECT IT. CONTAIN IT. COMPACT IT.



Perfect for small
footprints



Unique 3-point
latching design



FLEETGENIUS®



FleetGenius®
Glide Wheel



Ideal for Hi-Rise
Residential Buildings

Apt Compactor Specs and Features

FleetGenius® Apt Compactors are specifically designed to provide containment in a very small footprint. Ideal for a Hi-Rise Residential Building where trash is chute fed. The compactor packs in a mobile receiver container which can be rolled to the street for pickup. The FleetGenius® 3 point latching design ensures positive and durable connection to the receiver container. For added safety and ease of use, opt for The Glide Wheel option, which incorporates a brake system on the receiver container.

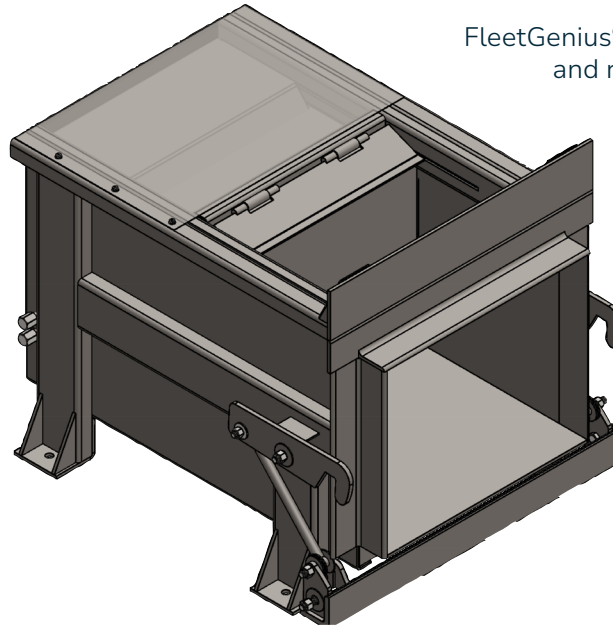

FleetGenius® Secure Side Latch Lever, a safe and reliable container locking system

- Ensures container is fully engaged and locked down
 - Prevents container jumping off connection when under pressure
- Can be installed on either side and can be moved to opposite side with standard tools
 - Simple retrofit latch pocks can be ordered to convert old containers

S-100 Bottom Latch Arm Option

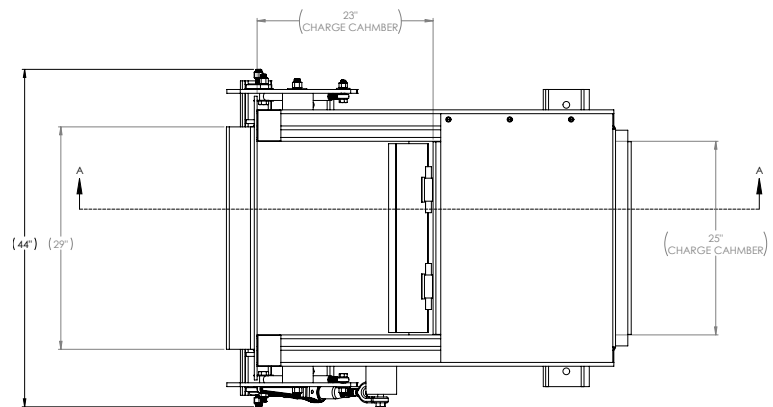
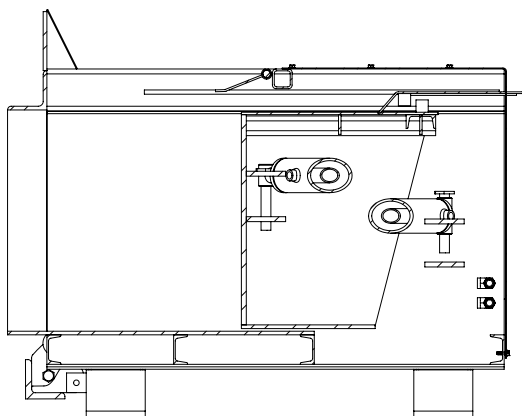
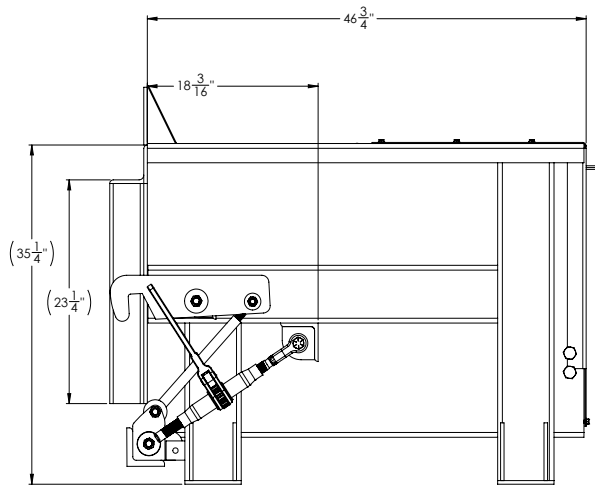

S125 w/ chute & Detailed Specs



S-100	SPECIFICATION	S-125
0.39 cu yd	Charge Box Capacity	0.59 cu yd
0.28 cu yd	WASTEC Rating	0.48 cu yd
22.5" L x 28" W	Clear Top Opening	35" L x 32" W
74 cu yd	Capacity per Hour	82 cu yd
14 sec	Cycle Time	20 sec
13,900 lbs	Normal Force	13,900 lbs
16,400 lbs	Pack out Force	16,400 lbs
23.2 psi	Normal Ram Race Force	23.2 psi
27.3 psi	Pact out Ram Force	27.3 psi
4"	Ram Penetration	4"
5 HP	Motor (208/230/460v 3 PH)	5 HP
120 VAC	Control Voltage	120 VAC
6 GPM	Hydraulic Pump Capacity	6 GPM
1650 psi	Normal System Pressure	1650 psi
1950 psi	Maximum System Pressure	1950 psi
2 each	Hydraulic Cylinders 2.5" Bore, 1.25" Rod	2 each
1850#	Weight	1975#

FLEETGENIUS® AT A GLANCE

At FleetGenius®, we've built our reputation on listening to our customers first, understanding their needs and then designing quality products that meet or exceed their expectations. FleetGenius® Apartment Compactors are ruggedly constructed to exacting standards to provide you with years of trouble-free performance without gimmicks or add ons you didn't ask for. In short, our compactors just work.

Genius? No. FleetGenius®.

WHO ARE WE?

- FleetGenius® has grown to include multiple environmental services companies with a combined experience spanning decades.
- Along with manufacturing our own line of commercial equipment, we also offer commercial container management that includes: inventory management, cart poly-welding, container washing, and more!
- Although we do deliver equipment via our own fleet, don't be fooled by our name! FleetGenius® is not a logistics company - we just support them!

Interested in learning more? Visit us at www.fleetgenius.com or give us a ring at 833-627-4872.

Eight Strategically Located Sales/Service Distribution Centers and SuperCenters

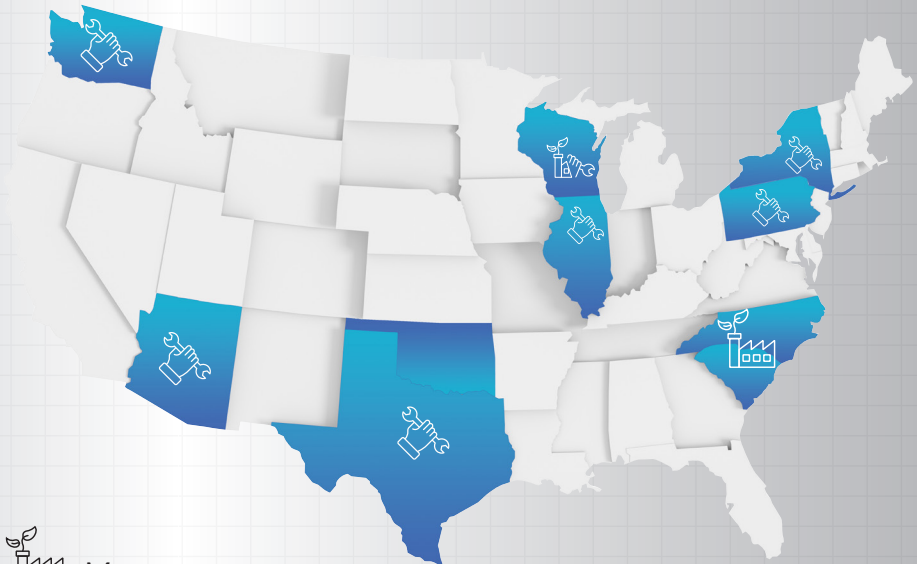

MANUFACTURING



SERVICE



LITE MFG & SERVICE



FLEETGENIUS®

www.fleetgenius.com